

Microminiature devices

transistors primarily intended for hybrid, thin and thick film circuits

book 1 parts 1 and 2

Type No.	Outline	Drawing reference	V_{CB0} (V)	Maximum V_{CE0} (V)	Rating $I_{C(AV)}$ (mA)	Rating T_j (°C)	P_{tot} at 25°C (mW)	P_{tot} min.	h_{FE} max.	at I_C (mA)	f_t min. (MHz)	$V_{CE(sat)}$ max. (V)	at I_C (mA)	at I_B (mA)	Nearest type in TO-18 envelope
----------	---------	-------------------	------------------	--------------------------	----------------------------	----------------------	------------------------------	-------------------	------------------	------------------	------------------------	------------------------------	------------------	------------------	--------------------------------

N-P-N TRANSISTORS

BCW31R BCW32R BCW33R	SOT-23	X1	30	20	100	150	200	110 200 420	220 450 800	2.0	300*	0.25	10	0.5	BC108A BC108B BC108C
BCW71R BCW72R	SOT-23	X1	50	45	100	150	200	110 200	220 450	2.0	300*	0.25	10	0.5	BC107A BC107B
BCX19 BCX20	SOT-23	X7	50 30	45 25	600	150	310	100	600	100	200*	0.62	500	50	BC337 BC338
BCX54 BCX55 BCX56	SOT-89	AM	45 60 100	45 50 80	1A	150	1W	40 40 40	250 180 160	150	130*	0.5	500	50	BD135 BD137 BD139
BFO17 BFO18 BFO19	SOT-89	AM	40 30 20	25 25 15	150 150 75	150	1W 1W 500	25 30 25	— — —	150 150 50	1.2G* 3.5G* 5.5G*	—	—	—	BFW16A BFR94 BFR96
BFR53	SOT-23	X7	18	10	50	150	180	25	—	50	2.0G*	—	—	—	BFW30
BFR92 BFR93	SOT-23	X7	20 15	15 12	25 35	150	180	25	—	14 30	5.0G*	—	—	—	BFR90 BFR91
BFS17R	SOT-23	X1	25	15	25	150	200	25	150	2.0	1300*	—	—	—	BFY90
BFS20R	SOT-23	X1	30	20	25	150	200	40	—	7.0	275	—	—	—	BF173
BFT25	SOT-23	X7	8	5	2.5	150	30	20	40*	1.0	1200	0.175	1.0	0.1	BFT24
BSS84	SOT-23	X7	120	80	100	150	200	20	—	4.0	60	0.7	4	0.4	BSS38
BSV52R	SOT-23	X1	20	12	100	150	200	40	120	10	400	0.25	10	1.0	BSX20

P-N-P TRANSISTORS

BCW29R BCW30R	SOT-23	X1	-30	-20	100	150	200	120 215	260 500	2.0	150*	-0.3	10	0.5	BC178A BC178B
BCW89R BCW70R	SOT-23	X1	-50	-45	100	150	200	120 215	260 500	2.0	150*	-0.3	10	0.5	BC177A BC177B
BCX17 BCX18	SOT-23	X7	-50 -30	-45 -25	500	150	310	100	600	100	100*	-0.62	500	50	BC327 BC328
BCX51 BCX52 BCX53	SOT-89	AM	-45 -60 -100	-45 -80 -80	1A	150	1W	40 40 40	250 180 160	150	50*	-0.5	500	50	BD136 BD138 BD140
BFT92 BFT93	SOT-23	X7	-20 -15	-15 -12	25 35	150	180	20	—	14 30	5G*	—	—	—	—
BSS63	SOT-23	X7	-110	-100	100	150	200	30	—	25	50	-0.25	25	2.5	BSS68

*Typical

N-CHANNEL JUNCTION FIELD EFFECT TRANSISTORS

Outline SOT-23

Type No.	Drawing reference	V_{GS0} (V)	V_{DS0} (V)	Maximum $\pm V_{DS}$ (V)	Rating I_G (mA)	T_j (°C)	P_{tot} at 25°C (mW)	$V_{(PIGS)}$ max. (V)	at I_D (nA)	$-I_{GSS}$ max. (nA)	I_{DSS} ($V_{GS} = 0$) min. (mA)	I_{DSS} max. (mA)	at V_{DS} (V)
BFR30 BFR31	X2	25	-25	25	5.0	150	200	-5.0 -2.5	0.5	0.2	4.0 1.0	10 5.0	10 10

OUTLINES and DIMENSIONS (millimetres)

A

B.S.3934 SO-16

DO-1
DO-2
DO-3

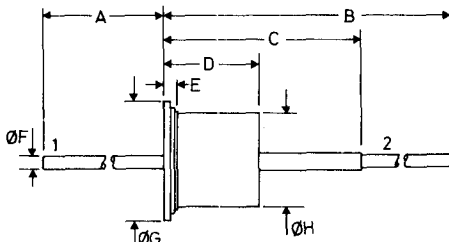

	1	2	A	B	C	D	E	ØF	ØG	ØH
	min.	min.	min.	min.	min.	max.	max.	max.	max.	max.
A1	a	k	35	51	17	7.7	1.6	1.1	9.6	7.1
A2	k	a	35	49	17	8.5	1.9	1.1	9.7	7.1
A3	k	a	35	51	17	7.7	1.6	1.1	9.6	7.1

B

B.S.3934 SO-10

DO-4

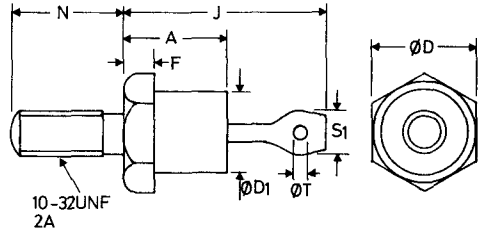

A 10.3 max.
ØD 11.1 max.
ØD1 9.3 max.
F 3.2

J 20.3 max.
N 11.5 max.
S1 4.8 max.
ØT 1.6 min.

	Stud	Eyelet
B1	k	a
B2	a	k

C

B.S.3934 SO-13

DO-5

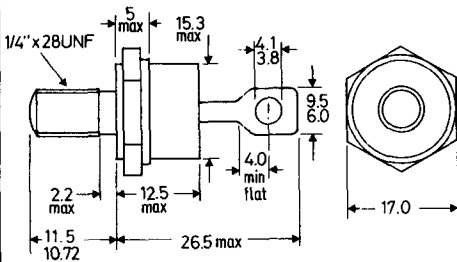

	Stud	Eyelet
C1	k	a
C2	a	k

D

DO-7
DO-14
DO-15

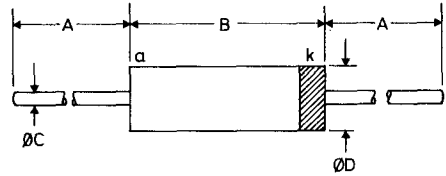

		A	B	ØC	ØD
		min.	max.	nom.	max.
D1	DO-7	25.4	7.6	0.52	2.5
D2	DO-14	25.4	7.6	0.5	3.3
D3	DO-15	25.4	6.4	0.8	3.2

E

DO-22
SOD-47

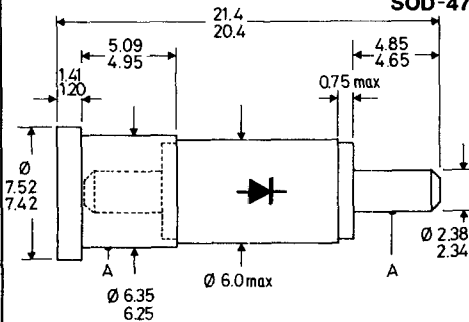

A = concentricity tolerance = ± 0.20

F

DO-30

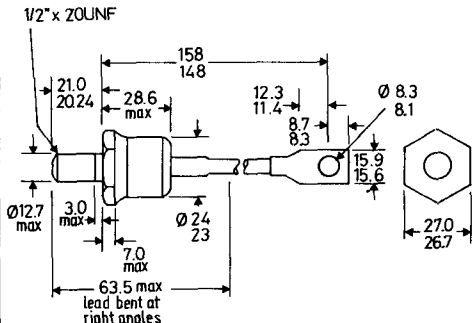

BZW86 Blue sleeve - anode to eyelet
BZW86R Red sleeve - anode to stud

These drawings give limited information for quick reference purposes. For equipment design more complete information should be obtained from individual data sheets in the Technical Handbook or from standard B.S. or JEDEC outline drawings.

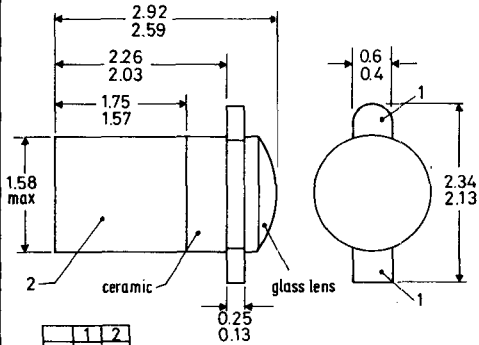
G**DO-31**

	1	2
G1	k	a
G2	e	c

For LED's the overall length = 3.60/2.97

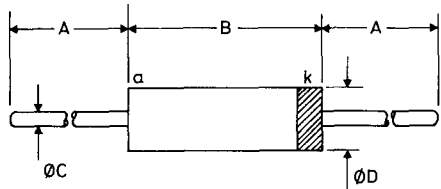
H**DO-35**

A	B	ØC	ØD
min.	max.	max.	max.
25.4	4.25	0.56	1.85

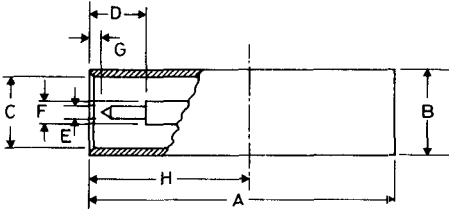
J**DO-37
SOD-49**

A	19.43/18.67	ØE	0.84/0.79
ØB*	5.59/5.49	ØF	1.57/1.52
ØC	4.80/4.72	G	0.71/0.15
D	3.73 min.	H	10.32 nom.

*These tolerances apply only over H

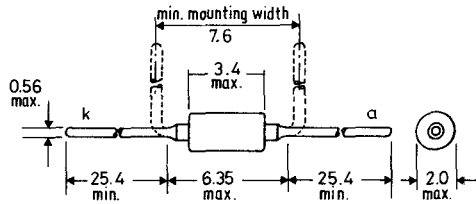
K**SOD-17**

Cathode indicated by the broad band of colour code

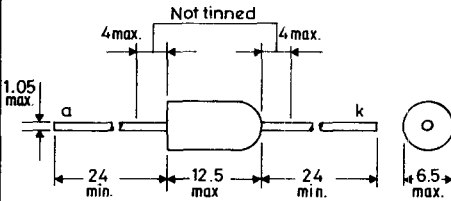
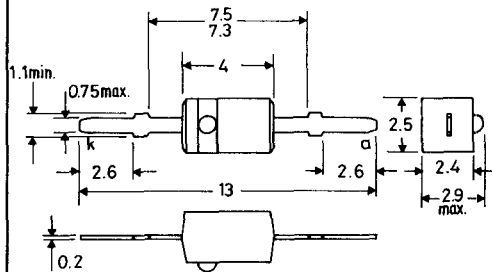
L**SOD-18****M****SOD-23**

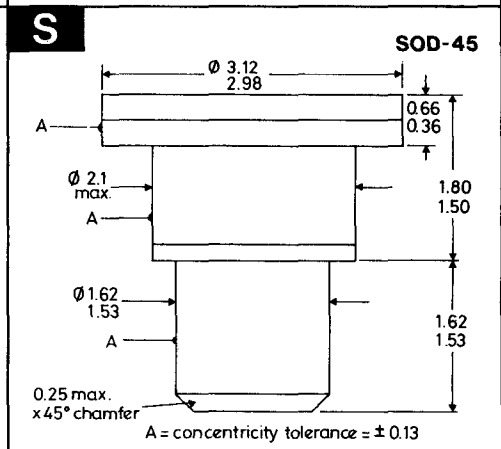
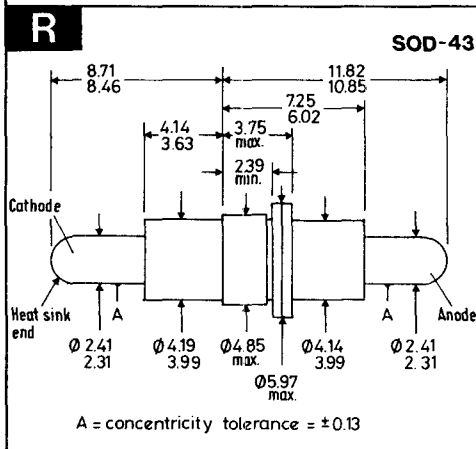
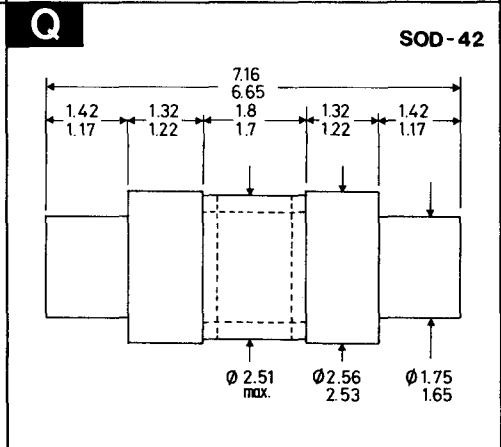
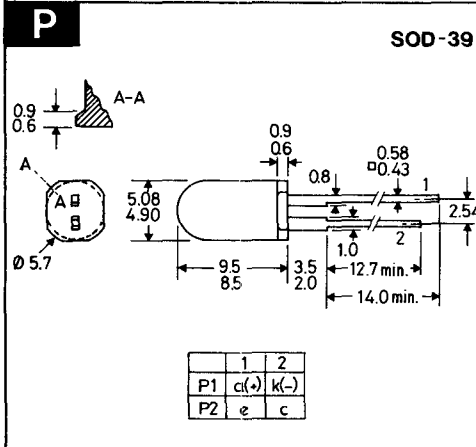
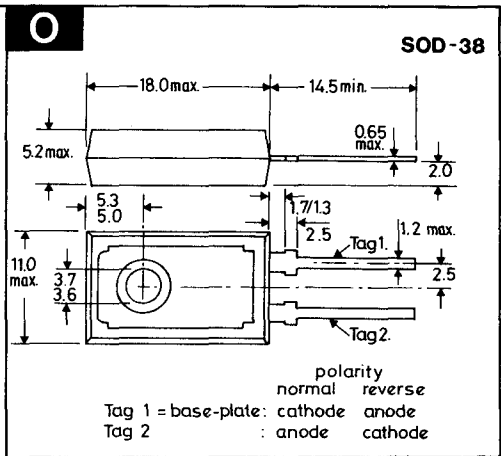
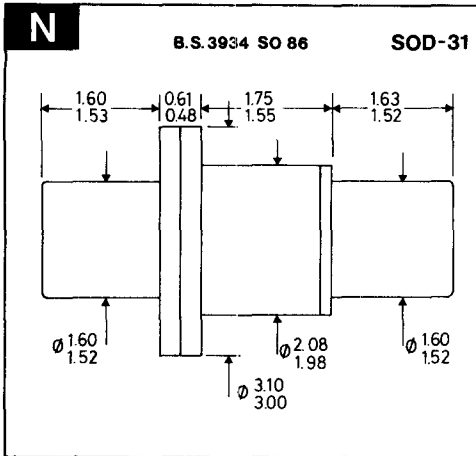

These drawings give limited information for quick reference purposes. For equipment design more complete information should be obtained from individual data sheets in the Technical Handbook or from standard B.S. or JEDEC outline drawings.

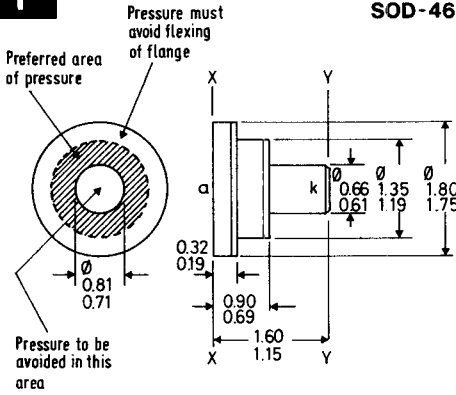
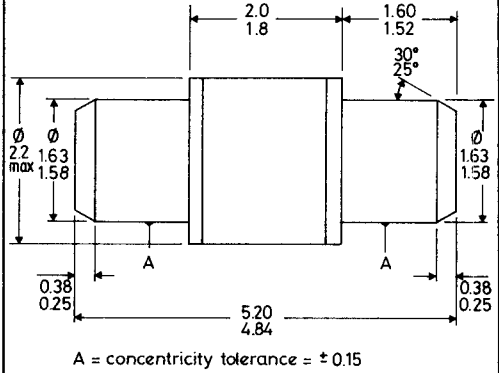
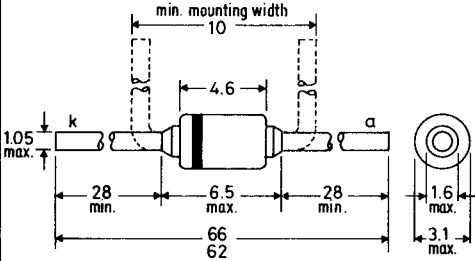
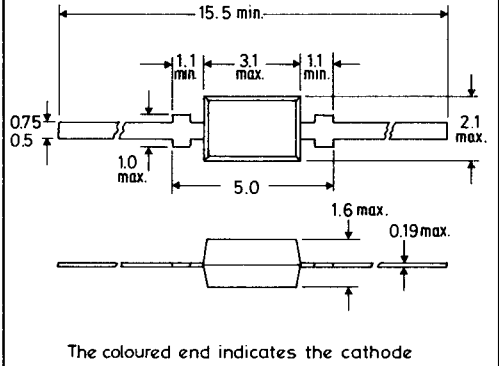
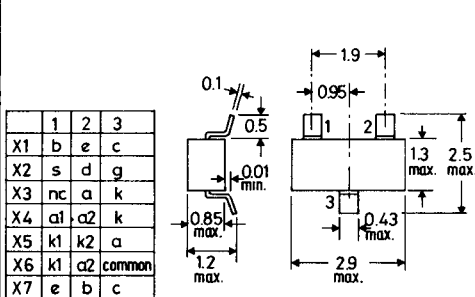
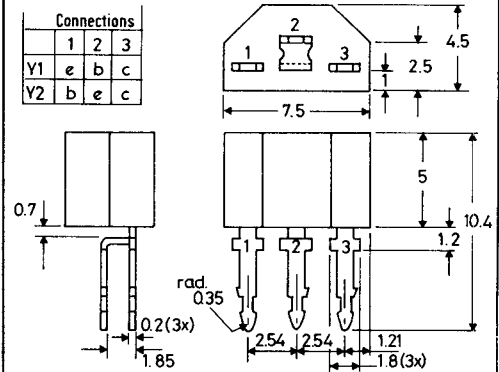
T**SOD-46****U****SOD-50****V****SOD-51****W****SOD-52****X****SOT-23****Y****SOT-25**

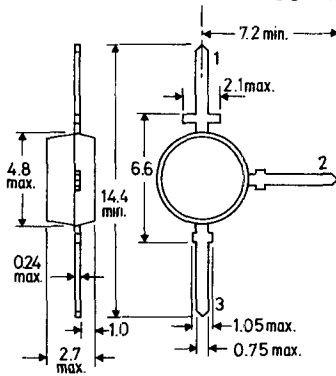
Z**SOT-37**

	1	2	3
Z1	c	b	e
Z2	c	e	b

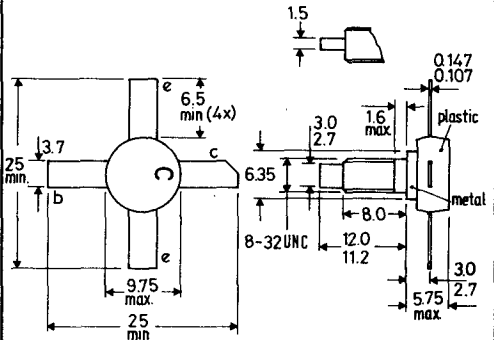
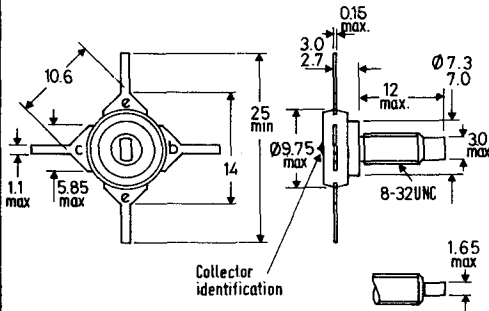
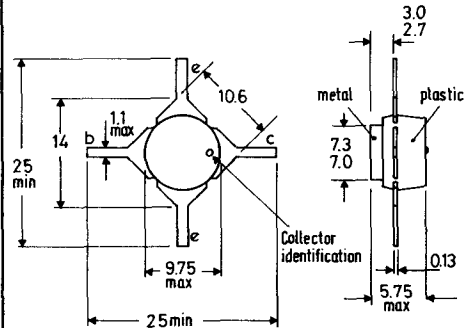
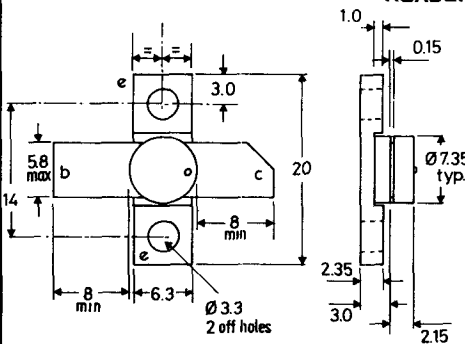
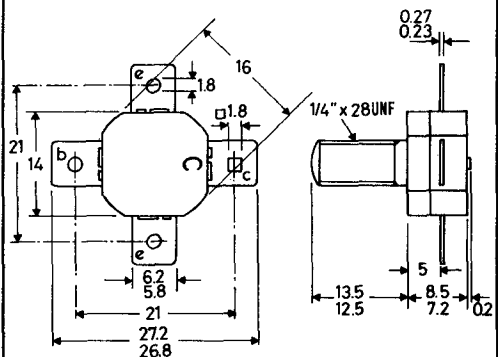
AC**SOT-48/2****AD****SOT-48/3****AE****SOT-48/4****AF****SOT-48
HEADER****AG****SOT-55**

These drawings give limited information for quick reference purposes. For equipment design more complete information should be obtained from individual data sheets in the Technical Handbook or from standard B.S. or JEDEC outline drawings.

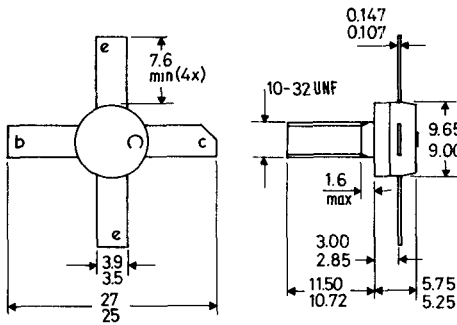
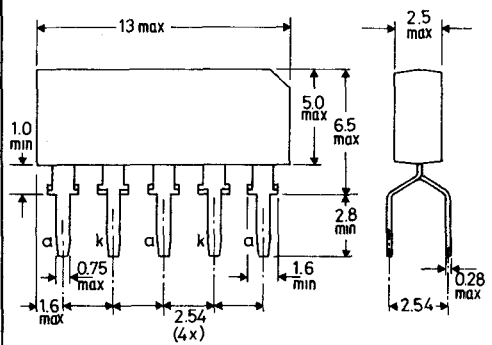
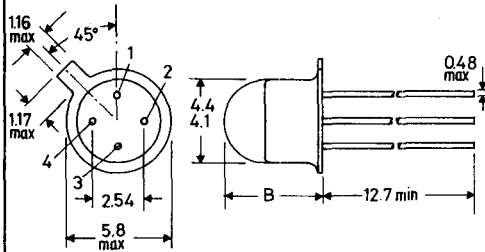
AH**SOT-56****AJ****SOT-60****AK****SOT-70**

	1	2	3	4	B max
AK1	a	—	k	—	5.08
AK2	e	b	c	—	4.5
AK3	Vp	IP	GND	OP	5.08

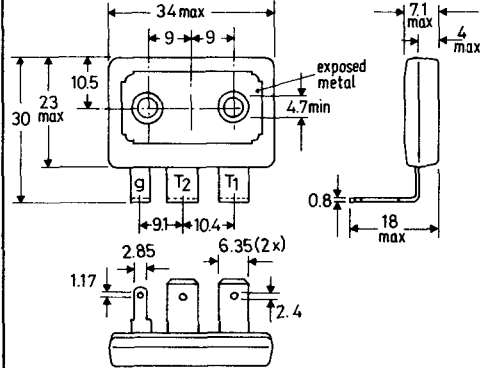
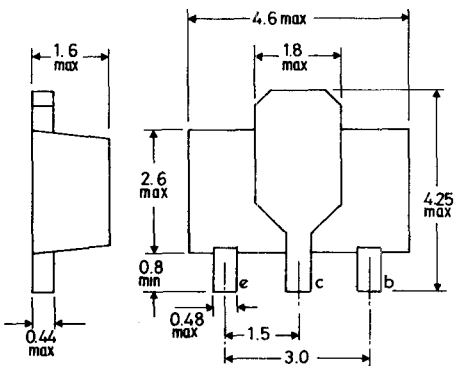
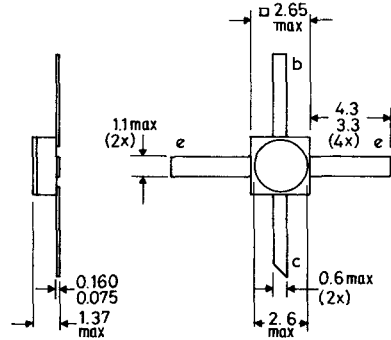
AL**SOT-80****AM****SOT-89****AN****SOT-100**

AO

SOT-103

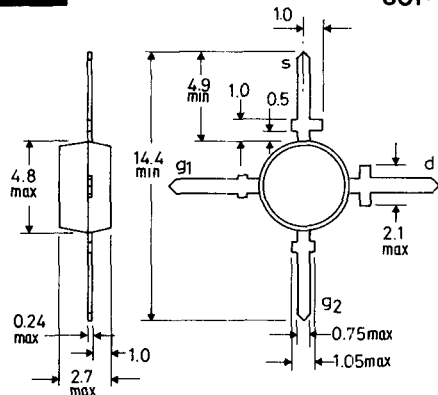

AP

SOT-105

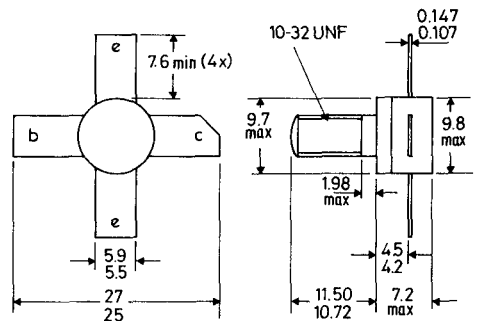

AQ

B.S.3934 SO-21/SB3-10 TO-1

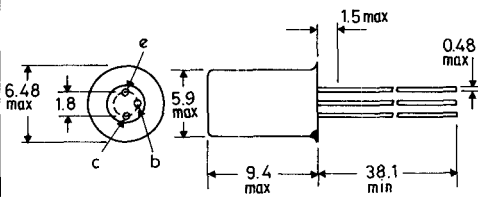

AR

B.S.3934 SO-5B/SB2-2 TO-3

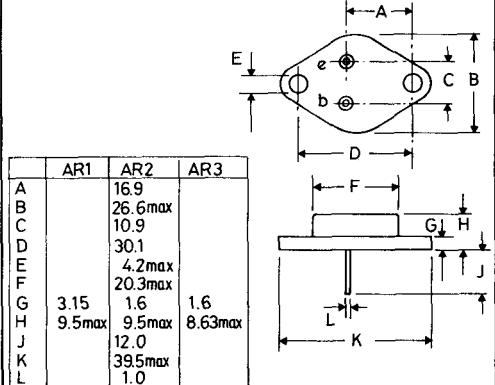

AS

B.S.3934 SO-3/SB3-3B TO-5

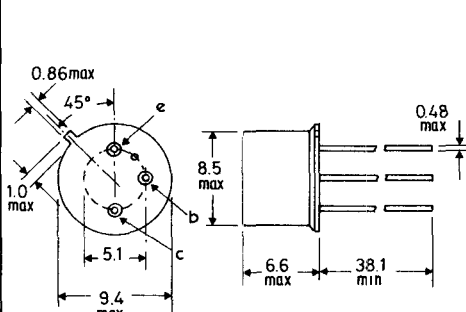

AS1: collector connected to case
AS2: base connected to case

AT

B.S.3934 SO-12A/SB3-6A TO-18

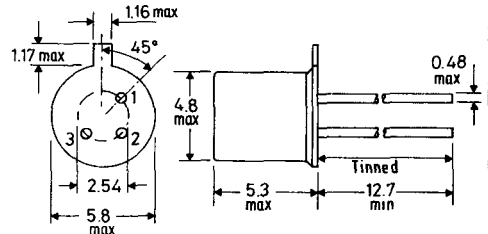

	1	2	3
AT1	e	b	c + env.
AT2	s	d	g + env.
AT3	d	g	s + env.
AT4	k	-	a
AT5	a	-	k
AT6	k	-	a

These drawings give limited information for quick reference purposes. For equipment design more complete information should be obtained from individual data sheets in the Technical Handbook or from standard B.S. or JEDEC outline drawings.

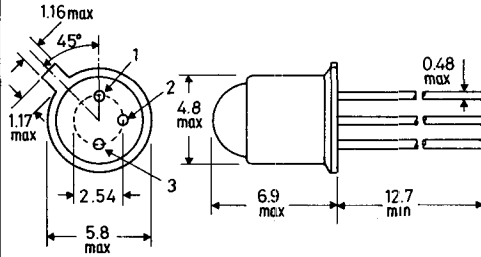
AU**TO-18**
(with lens)

	1	2	3
AU1	a	a	k
AU2	e	b	c+case
AU3	k	-	a

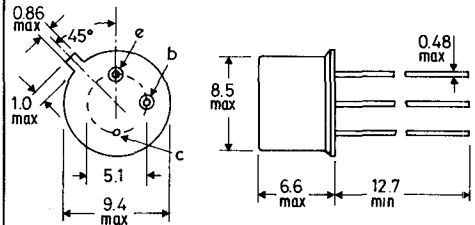
AV**B.S.3934 SO-3/SB3-3A TO-39**

AV1: b+case
 AV2: case isolated
 AV3: c+case
 AV4: e.cathode
 b.gate
 c.anode+case

AV5: e.b. cell connections
 c. metal case
 AV6: red spot indicates
 +ve connection

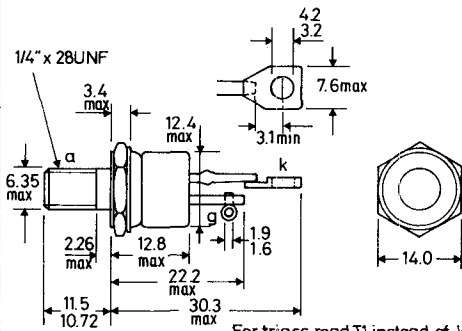
AW**B.S.3932 SO-36 TO-48**

For triacs read T1 instead of k
 T2 instead of a

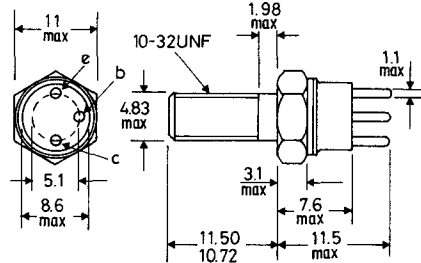
AX**TO-60**

Emitter connected to envelope

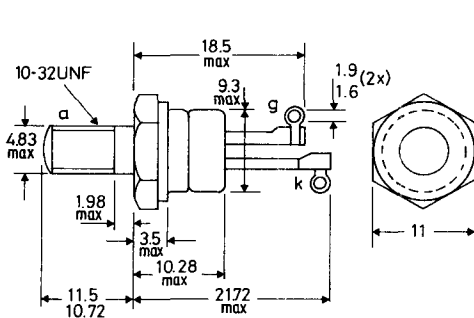
AY**B.S.3934 SO-35A TO-64**

For triacs read T1 instead of k
 T2 instead of a

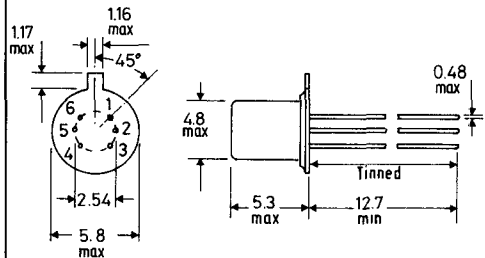
AZ**TO-71**

Pin	1	2	3	4	5	6
AZ1	e1	e2	c2	b2	b1	c1
AZ2	s1	d1	g1	s2	d2	g2

BA

B.S.3934 SO-12A/SB4-3 TO-72

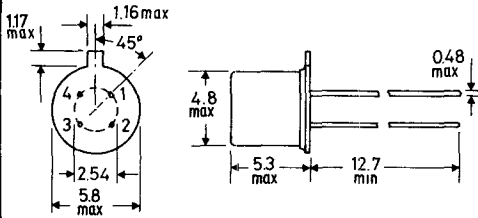

	1	2	3	4
BA1	b	e	c	s+envelope
BA2	e	b	c	s+envelope
BA3	s	d	g	screen+envelope
BA4	d	g	g	s+b+envelope
BA5	d	s	g	b+envelope
BA6	k	gk	ga	a

BBTO-92
variant

Pin	1	2	3
BB1	e	b	c
BB2	b	e	c
BB3	d	s	g
BB4	g	a	k
BB5	b	c	e

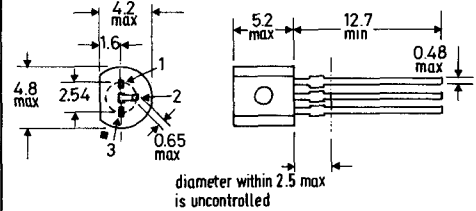
**BC**

B.S.3934 SO-30C TO-94

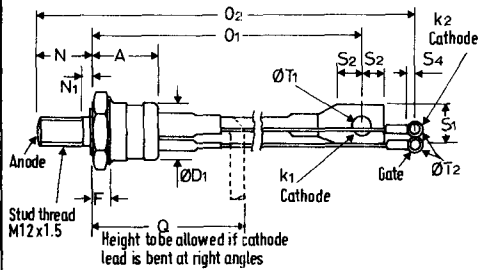

A	28.5max	O1	158 max	S4	3.8 min
ØD1	24.1max	O2	190max	ØT1	8.3max
F	8.9max	Q	63.5max	ØT2	4.2max
N	21.0max	S1	16.5max		
N1	3.0max	S2	9.6min		

BD

TO-103

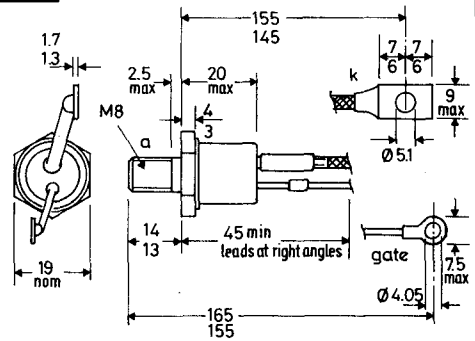
For triacs read T1 instead of k
T2 instead of a**BE**

TO-126

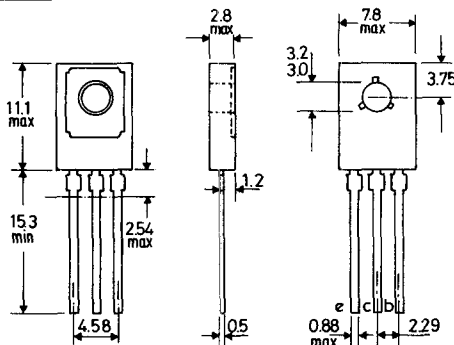
**BF**

TO-220

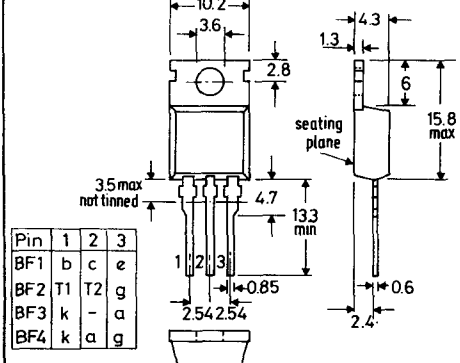

Pin	1	2	3
BF1	b	c	e
BF2	T1	T2	g
BF3	k	-	a
BF4	k	a	g

These drawings give limited information for quick reference purposes. For equipment design more complete information should be obtained from individual data sheets in the Technical Handbook or from standard B.S. or JEDEC outline drawings.

BG

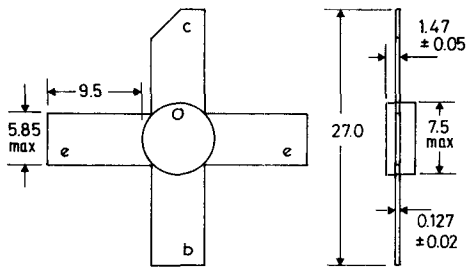

BH

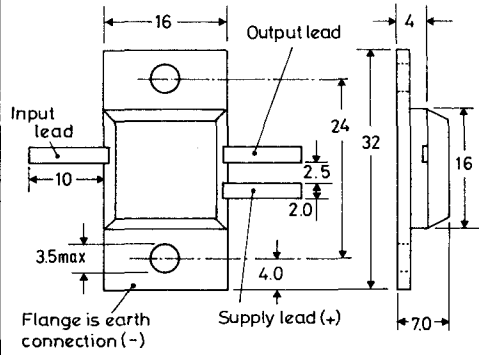

BJ

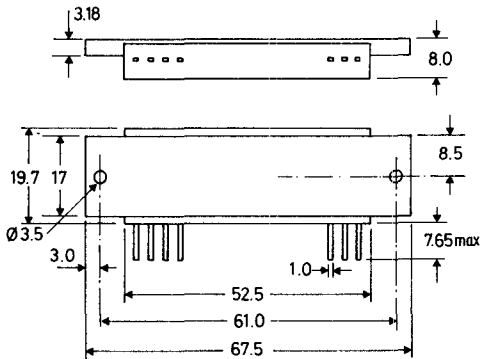

BK

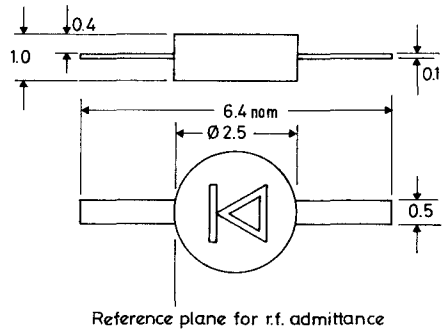

BL

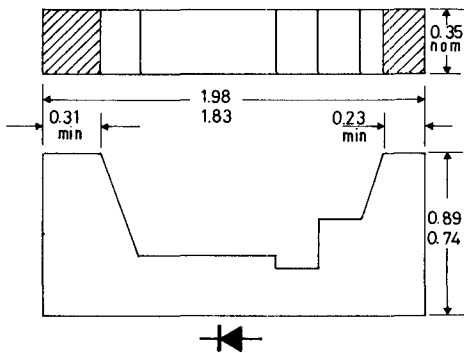

BM

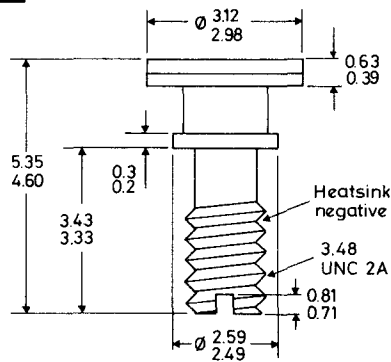

BN

B.S.3934

SO-26

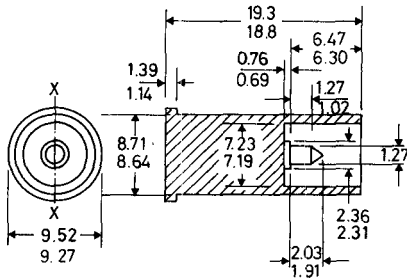

(All dimensions max.)

BO

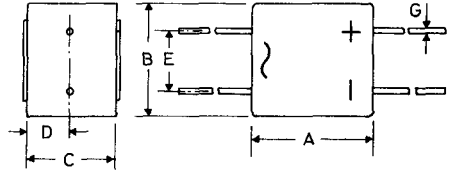

	BO1	BO2	BO3
A	12	20	12
B	10	19	10
C	8	15	8
D	4	7.5	4
E	5	10	5
F	58	60	48
G	0.75	1.0	1.1

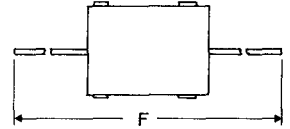

BP

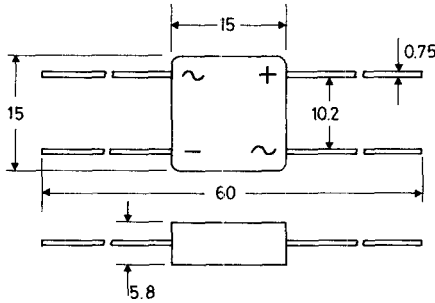

BQ

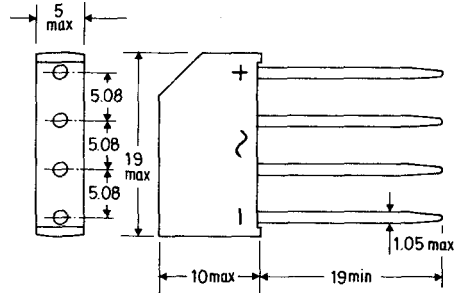

BR

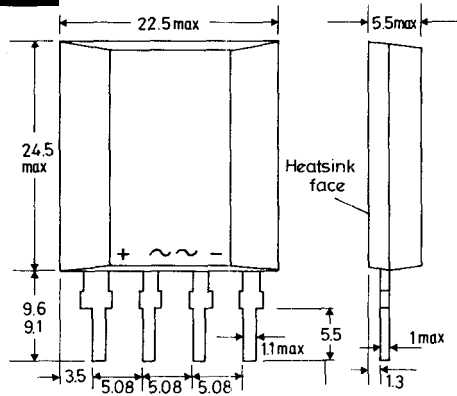

BS

B.S.3934 SO-67

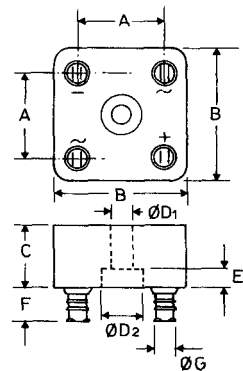

	BS1	BS2
	typ.	max.
A	23	21
B	35	34.6
C	17	15.2
ØD1	5	5.05
ØD2	11	11
E	5	3.7
F	9	9
ØG	4.8	4.8

These drawings give limited information for quick reference purposes. For equipment design more complete information should be obtained from individual data sheets in the Technical Handbook or from standard B.S. or JEDEC outline drawings.

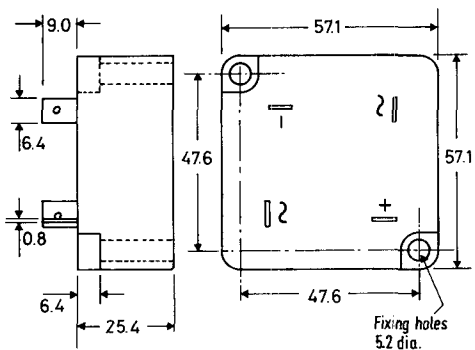
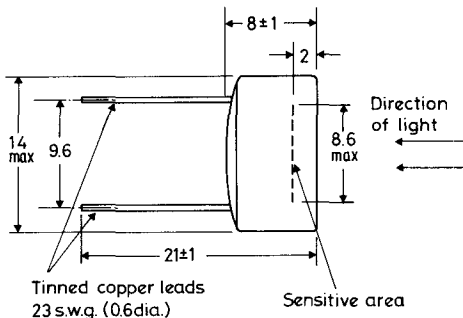
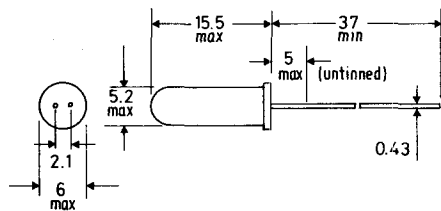
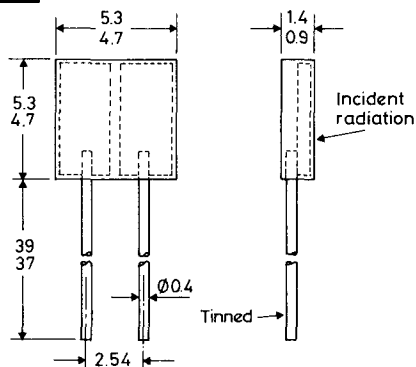
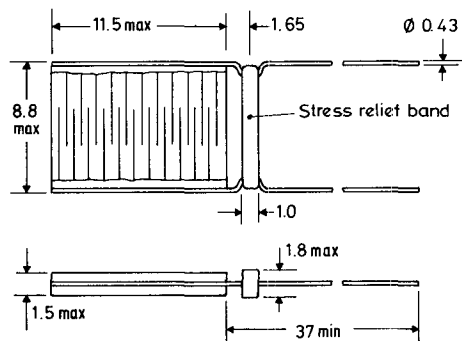
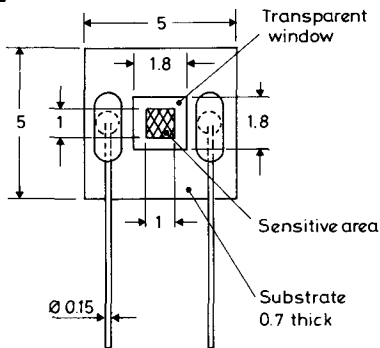
BT**BU****BV****BW****BX****BY**

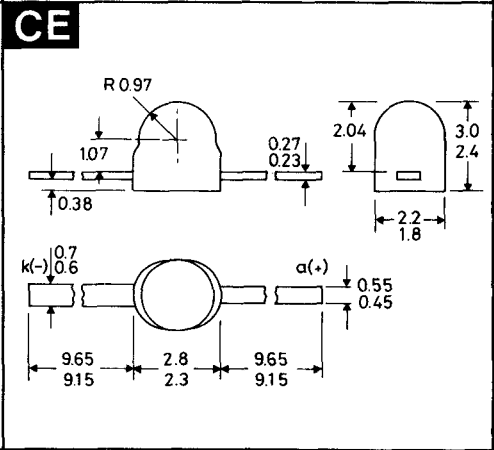
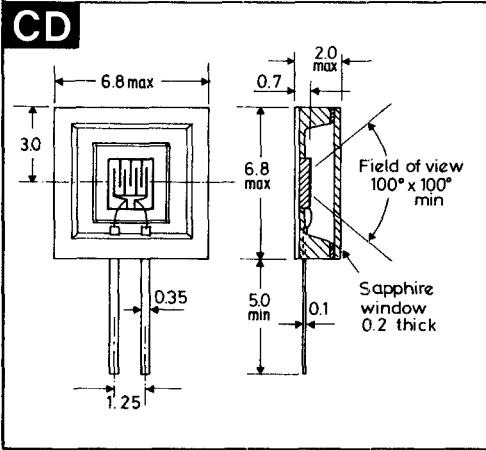
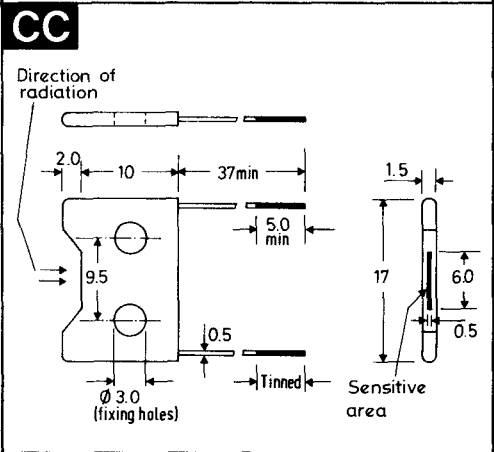
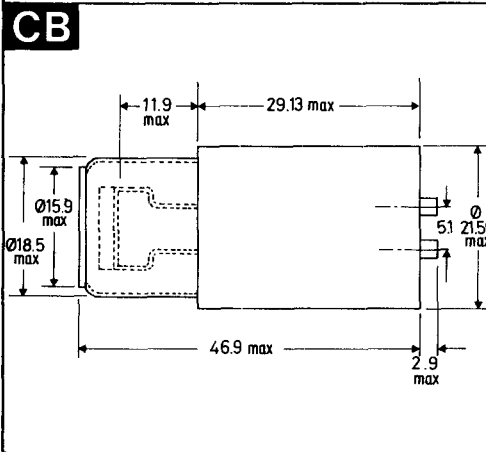
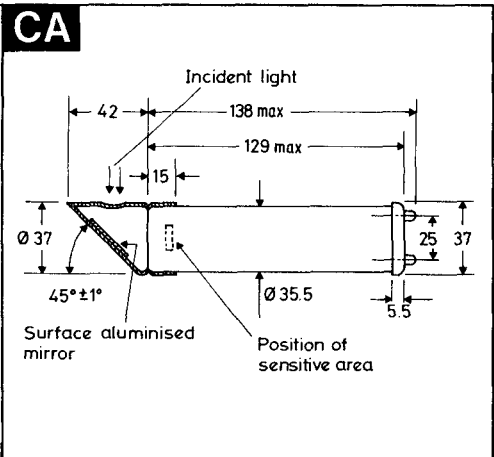
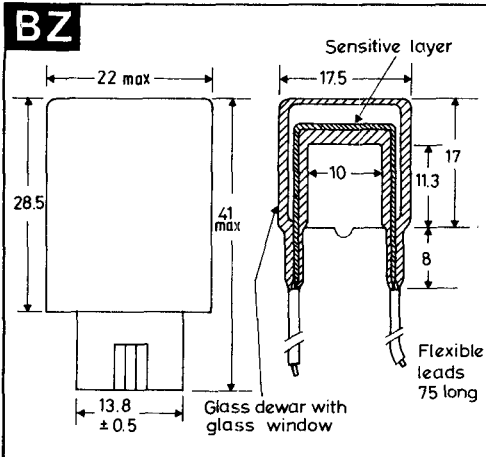

These drawings give limited information for quick reference purposes. For equipment design more complete information should be obtained from individual data sheets in the Technical Handbook or from standard B.S. or JEDEC outline drawings.

CF

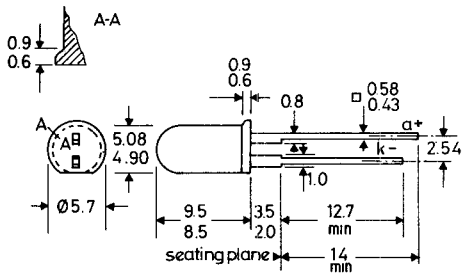

CG

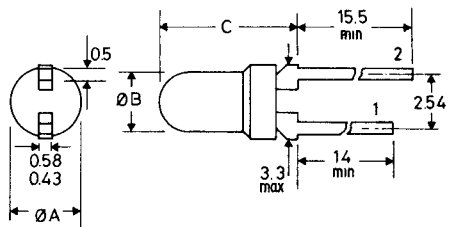

	1	2	$\varnothing A$	$\varnothing B$	C
CG1	k^-	a^+	3.0-3.17	2.4-2.6	5.8-6.3
CG2	a^+	k^-	3.0-3.17	2.4-2.6	5.8-6.3
CG3	k^-	a^+	3.3 max	2.65-3.17	4.8-6.3

CH

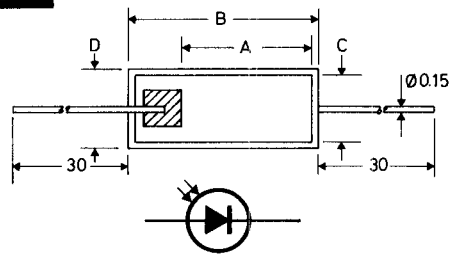

	CH1	CH2
A	2.2	3.5
B	3.35	4.55
C	0.95	1.85
D	1.25	2.15

CJ

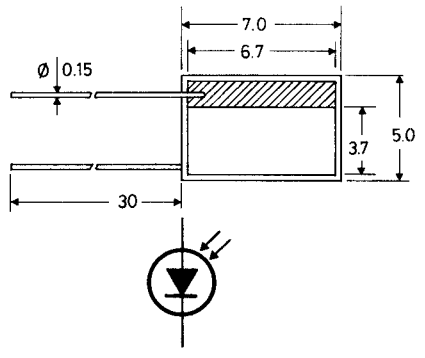

CK

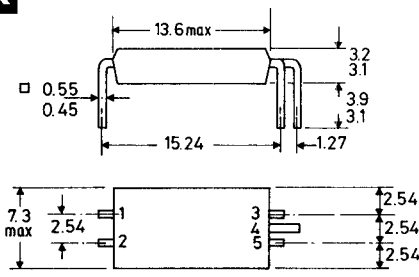

Pin	1	2	3	4	5
CK1	a	k	b	c	e
CK2	k	a	e	omitted	c

CL

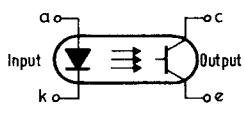
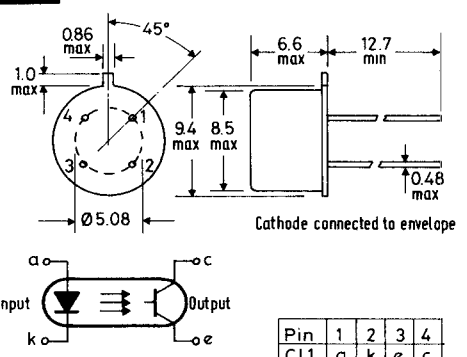

Pin	1	2	3	4
CL1	a	k	e	c
CL2	e	c	a	k

CM

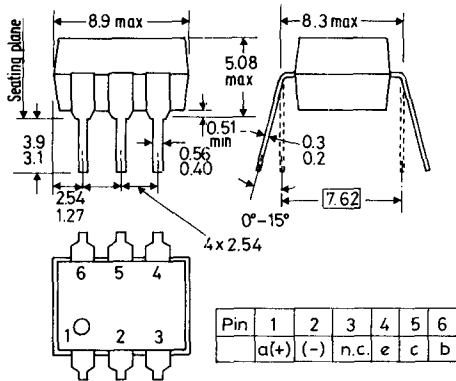

CN

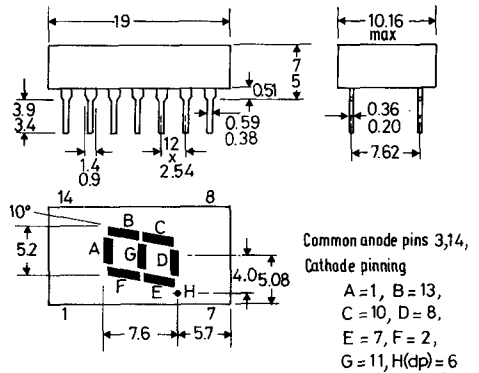

CO

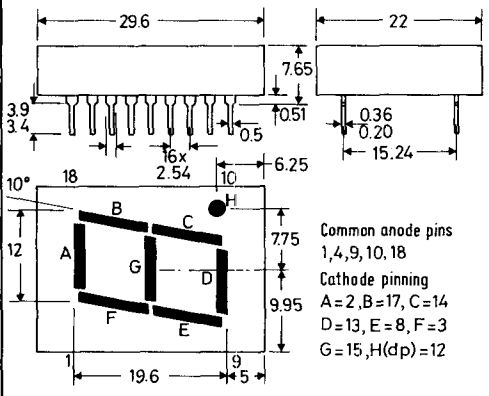

These drawings give limited information for quick reference purposes. For equipment design more complete information should be obtained from individual data sheets in the Technical Handbook or from standard B.S. or JEDEC outline drawings.