

Features

- Ideally Suited for Automatic Insertion
- Complementary PNP Types Available (BC856W-BC858W)
- For Switching and AF Amplifier Applications
- Available in Lead Free/RoHS Compliant Version (Note 3)

Mechanical Data

- Case: SOT-323
- Case Material: Molded Plastic. UL Flammability Classification Rating 94V-0
- Moisture Sensitivity: Level 1 per J-STD-020C
- Terminals: Solderable per MIL-STD-202, Method 208
- Also Available in Lead Free Plating (Matte Tin Finish annealed over Alloy 42 leadframe). Please see Ordering Information, Note 6, on Page 2
- Pin Connections: See Diagram
- Marking Codes (See Table Below & Diagram on Page 2)
- Ordering & Date Code Information: See Page 2
- Weight: 0.006 grams (approximate)

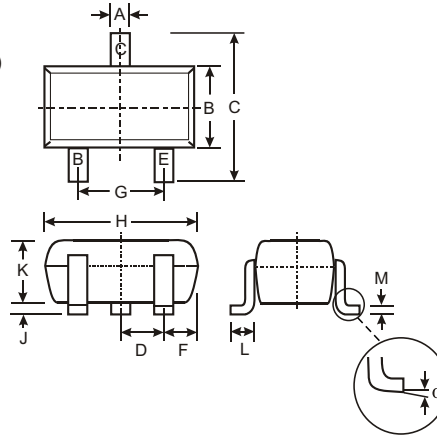

SOT-323		
Dim	Min	Max
A	0.25	0.40
B	1.15	1.35
C	2.00	2.20
D	0.65 Nominal	
E	0.30	0.40
G	1.20	1.40
H	1.80	2.20
J	0.0	0.10
K	0.90	1.00
L	0.25	0.40
M	0.10	0.18
α	0°	8°
All Dimensions in mm		

Datasheet.Technology

Marking Code (Note 2)			
Type	Marking	Type	Marking
BC846AW	K1Q	BC847CW	K1M
BC846BW	K1R	BC848AW	K1J, K1E, K1Q
BC847AW	K1E, K1Q	BC848BW	K1K, K1F, K1R
BC847BW	K1F, K1R	BC848CW	K1L, K1M

Maximum Ratings @ T_A = 25°C unless otherwise specified

Characteristic	Symbol	Value	Unit
Collector-Base Voltage	V _{CBO}	BC846 80	V
		BC847 50	
		BC848 30	
Collector-Emitter Voltage	V _{CEO}	BC846 65	V
		BC847 45	
		BC848 30	
Emitter-Base Voltage	BC846, BC847 BC848	V _{EBO} 6.0 5.0	V
Collector Current	I _C	100	mA
Peak Collector Current	I _{CM}	200	mA
Peak Emitter Current	I _{EM}	200	mA
Power Dissipation (Note 1)	P _d	200	mW
Thermal Resistance, Junction to Ambient (Note 1)	R _{θJA}	625	°C/W
Operating and Storage Temperature Range	T _J , T _{STG}	-65 to +150	°C

- Notes:
1. Device mounted on FR-4 PCB, 1 inch x 0.85 inch x 0.062 inch; pad layout as shown on Diodes Inc. suggested pad layout document AP02001, which can be found on our website at <http://www.diodes.com/datasheets/ap02001.pdf>.
 2. Current gain subgroup "C" is not available for BC846W.
 3. No purposefully added lead.

Electrical Characteristics @ T_A = 25°C unless otherwise specified

Characteristic	Symbol	Min	Typ	Max	Unit	Test Condition
Collector-Base Breakdown Voltage (Note 4)	BC846 BC847 BC848 V _{(BR)CBO}	80 50 30	— — —	— — —	V	I _C = 10μA, I _B = 0
Collector-Emitter Breakdown Voltage (Note 4)	BC846 BC847 BC848 V _{(BR)CEO}	65 45 30	— — —	— — —	V	I _C = 10mA, I _B = 0
Emitter-Base Breakdown Voltage (Note 4)	BC846, BC847 BC848 V _{(BR)EBO}	6 5	—	—	V	I _E = 1μA, I _C = 0
DC Current Gain Current Gain Group A B C (Note 4)	h _{FE}	110 200 420	180 290 520	220 450 800	—	V _{CE} = 5.0V, I _C = 2.0mA
Collector-Emitter Saturation Voltage (Note 4)	V _{CE(SAT)}	—	90 200	250 600	mV	I _C = 10mA, I _B = 0.5mA I _C = 100mA, I _B = 5.0mA
Base-Emitter Saturation Voltage (Note 4)	V _{BE(SAT)}	—	700 900	—	mV	I _C = 10mA, I _B = 0.5mA I _C = 100mA, I _B = 5.0mA
Base-Emitter Voltage (Note 4)	V _{BE(ON)}	580 —	660 —	700 770	mV	V _{CE} = 5.0V, I _C = 2.0mA V _{CE} = 5.0V, I _C = 10mA
Collector-Cutoff Current (Note 4)	I _{CBO} I _{CBO}	— —	— —	15 5.0	nA μA	V _{CB} = 30V V _{CB} = 30V, T _A = 150°C
Gain Bandwidth Product	f _T	100	300	—	MHz	V _{CE} = 5.0V, I _C = 10mA, f = 100MHz
Collector-Base Capacitance	C _{CBO}	—	3.0	4.5	pF	V _{CB} = 10V, f = 1.0MHz
Noise Figure	NF	—	—	10	dB	V _{CE} = 5V, I _C = 200μA, R _S = 2.0kΩ, f = 1.0kHz, Δf = 200Hz

Notes: 4. Short duration pulse test to minimize self-heating effect.

Ordering Information (Note 5)

Device	Packaging	Shipping
BC84xxW-7*	SOT-323	3000/Tape & Reel

Notes: 5. For Packaging Details, go to our website at <http://www.diodes.com/datasheets/ap02007.pdf>.

*xx = device type, e.g. BC846AW-7.

6. For Lead Free/RoHS Compliant version part number, please add "-F" suffix to the part number above. Example: BC846AW-7-F.

Marking Information

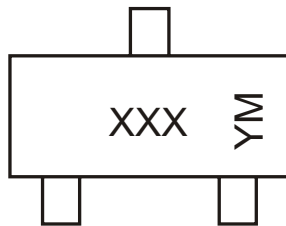

XXX = Product Type Marking Code (See Page 1), e.g. K1Q = BC846AW
 YM = Date Code Marking
 Y = Year ex: N = 2002
 M = Month ex: 9 = September

Date Code Key

Year	1998	1999	2000	2001	2002	2003	2004	2005	2006	2007	2008	2009
Code	J	K	L	M	N	P	R	S	T	U	V	W
Month	Jan	Feb	March	Apr	May	Jun	Jul	Aug	Sep	Oct	Nov	Dec
Code	1	2	3	4	5	6	7	8	9	O	N	D

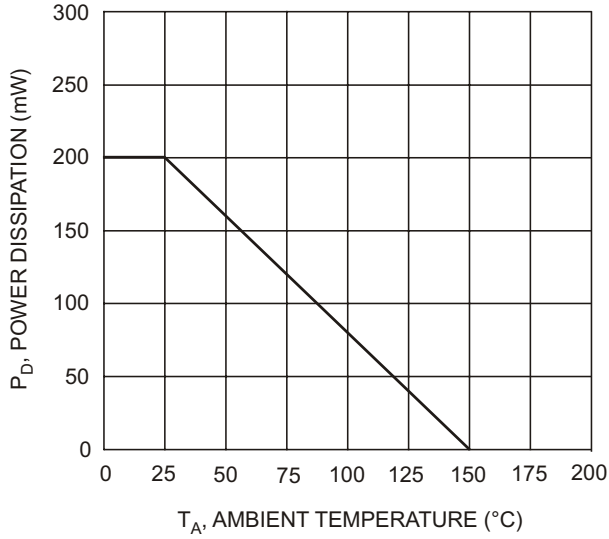

Fig. 1, Max Power Dissipation vs Ambient Temperature

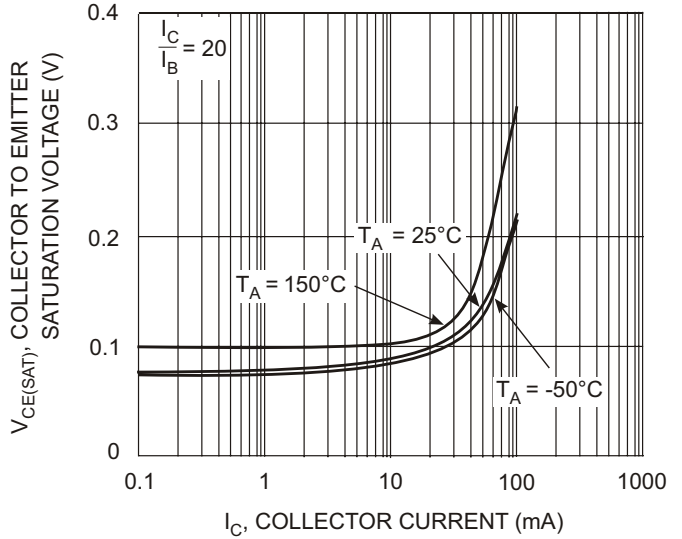

Fig. 2 Collector Emitter Saturation Voltage vs. Collector Current

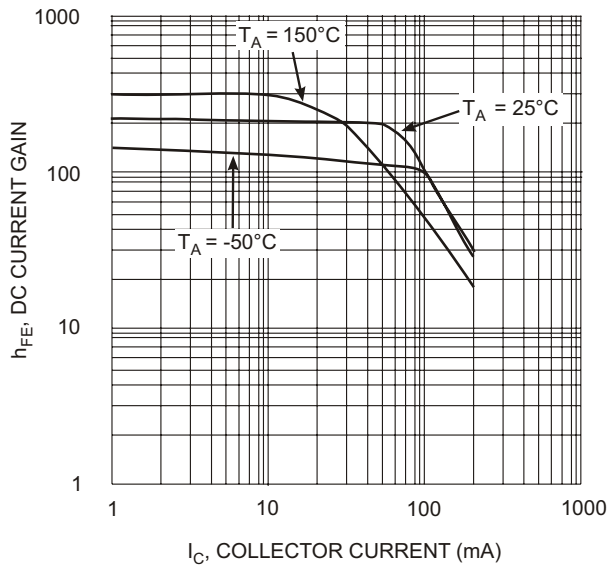

Fig. 3, DC Current Gain vs. Collector Current

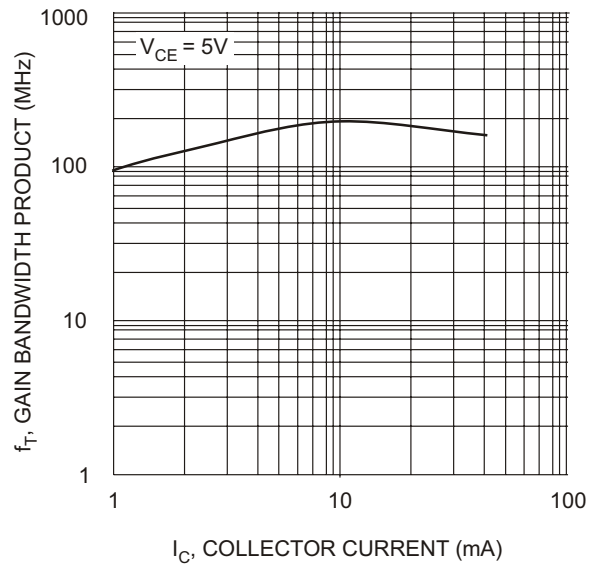

Fig. 4, Gain Bandwidth Product vs Collector Current